

Verb doubling and the order of operations at PF: Insights from Asante Twi

Johannes Hein*

Abstract

Most work on predicate clefts seems to presuppose the implication that if a language shows verb doubling when the verb alone is fronted it also shows verb doubling when the verb is fronted together with its internal argument(s). In this paper, I present data from Asante Twi, where the verb is doubled in the former case but there is *do*-support in the latter instead. I argue that the patterns can be accounted for by varying orders of the operations Chain Reduction (CR) and Head-to-Head Movement (HHM) at PF. CR may either bleed HHM, giving rise to consistent *do*-support (as in German) or counterbleed it, leading to consistent verb doubling (as in Hebrew). The Asante Twi pattern then is a result of neutralisation due to the inability of \bar{A} -head movement to form chains. The account provides a unified analysis of verb doubling and *do*-support in predicate clefts, which derives all attested patterns to the exclusion of the unattested reverse Asante Twi pattern.

1. The issue

The Asante Twi dialect of Akan, a Kwa language spoken in Ghana, has a verbal focus construction where two copies of the main verb are overtly realised: one clause-initially and the other in its base position. This construction, also often termed *predicate cleft* (though see Aboh 2006), is quite common in West African languages (e.g. Vata and Nweh, Koopman 1984, 1997; Yoruba, Manfredi 1993; Gungbe, Aboh 1998, 2006; Tuki, Biloa 1997; Buli, Hiraiwa 2005; Ewegbe, Ameka 1992; Gã, Kropp Dakubu 2005; to name only a few). Furthermore, it is also attested in languages outside of Africa (e.g. Hebrew, Landau 2006; Yiddish,

* I am indebted to my informant Sampson Korsah for providing his native speaker grammaticality judgements on all Asante Twi (and Gã) examples in this article. Further, I would like to thank Martin Salzmann, Andrew Murphy, Gereon Müller, Joanna Zaleska, Doreen Georgi, Fabian Heck, and the participants of the colloquium ‘Theory of Grammar’ and the ‘Workshop on Replicative Processes in Grammar’ in Leipzig for helpful comments and discussions. All errors are, of course, mine.

Cable 2004; Russian, Abels 2001, Aboh & Dyakonova 2009; Polish, Bondaruk 2009, 2012; Brazilian Portuguese, Bastos-Gee 2009; Spanish, Vicente 2007, 2009; Hungarian, Ürögdi 2006; Vietnamese, Trinh 2011) where it is largely used to express verbal topics.

Predicate clefts in Asante Twi show an interesting asymmetry. Consider the sentences in (1) (tones will generally not be marked throughout this article unless stated otherwise).

- (1) a. *Sí-(é) na Kofi á-sí/*á-yɔ́ dán.*
 build-NMLZ FOC Kofi PRF-build/PRF-do house
 ‘Kofi has BUILT a house.’
- b. *Dán sí-é na Kofi *á-sí/á-yɔ́*
 house build-NMLZ FOC Kofi PRF-build/PRF-do
 ‘Kofi has BUILT A HOUSE.’
- c. *Kofi á-si dán.*
 Kofi PRF-build house
 ‘Kofi has built a house.’
- d. *Dán na Kofi á-sí.*
 house FOC Kofi PRF-build
 ‘It is a house that Kofi has built.’

Examples (1a, b) are both predicate cleft constructions where a (nominalised) verbal constituent – the verb alone (1a) or the verb with its internal argument (1b) – appears in focus position. As in many other West African languages, there are two copies of the main verb in (1a), one of them fronted and nominalised/non-finite, the other in its base position and finite. In (1b), on the other hand, the finite copy of the main verb is replaced by a dummy verb *yɔ́* (translatable as ‘do’), while the only copy of the main verb appears in the fronted nominalised object-verb complex.¹ The data in (1c, d) provide examples of a standard transitive sentence exemplifying the basic SVO word order and a standard object focus construction, respectively.

This kind of asymmetry is unexpected both conceptually and typologically. If verb doubling is necessary and possible because the tense and aspect features

¹Nominalisation is obligatory with focussed verb phrases while it is optional with focussed bare verbs. This difference, however, is not tied to the choice of *yɔ́* vs. main verb in base position: *Yɔ́* is ungrammatical with a fronted bare verb, be it nominalised or not. Likewise, a fronted non-nominalised verb phrase is ungrammatical, irrespective of whether there is *yɔ́* or a copy of the main verb in base position.

need a host in order to be spelled out (see Landau 2006), then why is it not used with VP focus? Likewise, if a strategy like *do*-support exists as a Last Resort in the language to avoid violation of a constraint against stray affixes (the Stray Affix Filter, Lasnik 1981) when the VP is fronted, why is it not used with bare V fronting? In other words, one would expect the language to be symmetric in using only one repair mechanism for the two similarly illicit structural configurations rather than having a different one for each of them. Typologically, this expectation seems to be met: Each of the languages discussed in the literature on predicate clefts instantiates verb doubling in V fronting and VP fronting, if both types of fronting are available. A prime example of such a language with symmetric verb doubling is Hebrew (2).

- (2) a. *Liknot*, hi *kanta* et ha-*praxim*.
 buy.INF she buy.PST ACC DEF-flowers
 ‘As for buying, she bought the flowers.’
 b. *Liknot* et ha-*praxim*, hi *kanta*.
 buy.INF ACC DEF-flowers she buy.PST
 ‘As for buying the flowers, she bought (them).’ (Landau 2006: 37)

In Hebrew, the main verb is doubled when a verbal constituent appears clause initially, irrespective of whether this constituent is a bare verb (2a) or a verb phrase (2b).

The Asante Twi data raise two questions, one typological and the other theoretical: (i) If *do*-support and verb doubling are two legitimate strategies to deal with displaced predicates in one and the same language as evidenced by Asante Twi, are there languages that instantiate its mirror image, namely exhibiting *do*-support with V fronting and verb doubling with VP fronting, and (ii) can the attested asymmetric and symmetric patterns be derived under Minimalist assumptions about syntax and PF, and if yes, how?

The first question may be answered negatively. To the best of my knowledge my knowledge, there are no languages that show verb doubling in VP fronting contexts but *do*-support with V fronting. The attested patterns are shown in (3).

Also, I will have nothing to say about the different order of verb and object in a nominalised vs. verbal VP (OV vs. standard VO) as this issue is orthogonal to the questions pursued in this paper.

(3) Attested repair strategy patterns in predicate displacement

		V fronting	
		V doubling	<i>do</i> -support
VP fronting	<i>do</i> -support V doubling	Asante Twi Hebrew	(German ²) —

The remainder of the present article is an answer to the second question. After showing in section 2 that Asante Twi predicate clefts involve \bar{A} -movement, I argue in section 3 against an analysis with prosodically conditioned $\gamma\mathcal{O}$ insertion as proposed for the phonologically and semantically similar element $\gamma\mathcal{E}$ by Kandybowicz (2015). An analysis inspired by parallel chains is presented in section 4, which derives the attested patterns to the exclusion of the unattested one by means of the order of the operations Head-to-Head Movement (HHM) and Chain Reduction (CR), which are both taken to apply at PF. The analysis will be extended to languages that move $V\text{-}\nu/\nu\text{P}$ instead of V/VP in section 5 and to remnant $\text{VP}/\nu\text{P}$ movement as found in German and Polish in section 6. Section 7 summarises and concludes the paper.

A remark on terminology: I will use the terms (bare) V fronting and VP fronting to refer to surface configurations where a verb alone or respectively a verb and its internal argument(s) occur sentence-initially with a focus or topic interpretation, irrespective of whether the fronted constituent is syntactically a V-head or a complex $V\text{-}\nu$ -head and a VP or a νP . The terms $V(\text{P})$ or $\nu(\text{P})$ movement will be used to denominate the actual syntactic constituents in displacement.

2. The syntactic structure of predicate clefts

2.1. Movement or base generation

There have been two main lines of syntactic analysis of predicate clefts in the literature: base generation and \bar{A} -movement. On the one hand, Cable (2004) argues that the fronted constituent in predicate clefts in Yiddish (and at least in some varieties of Brazilian Portuguese, see also Bastos-Gee 2009) must be base generated in a peripheral topic position rather than moved there from a

²On the pattern in German verb (phrase) topicalisation, see section 6.

clause-internal base position. (But it may then move to higher topic positions later on.)

On the other hand – building on Koopman (1984) – Landau (2006) and Vicente (2007, 2009) propose movement-based analyses for predicate cleft constructions in Hebrew and Spanish, respectively, where predicate cleft dependencies show the characteristics of \bar{A} -movement: they can cross finite clause boundaries and are sensitive to islands such as the *wh*-island, the complex NP island, the subject island, and the adjunct island (to varying degrees, at least in Hebrew). Also, Cable (2004) explicitly acknowledges that Hebrew predicate clefts most plausibly involve movement because no evidence in favour of a base generation approach can be found there.

In the case of Asante Twi, predicate clefts involve movement rather than base generation. There are two pieces of evidence in favour of this position. First, the dependency can cross finite clause boundaries (4) and is sensitive to islands such as *wh*-islands (5), complex NP islands (6), subject islands (7), relative clause islands (8), and adjunct islands (9).³

- (4) a. Sí-(é) na Ama ká-a sé Kofi á-si dán.
 build-NMLZ FOC Ama say-PST COMP Kofi PRF-build house
 ‘Ama said that Kofi has BUILT a house.’
 b. Dán sí-é na Ama ká-a sé Kofi á-yó.
 house build-NMLZ FOC Ama say.PST COMP Kofi PRF-do
 ‘Ama said that Kofi has BUILT A HOUSE.’
- (5) *Wh-island*
 a. *Sí-(é) na Ama bísá-a se dabén na Kofi sí-i
 build-NMLZ FOC Ama ask-PST COMP when FOC Kofi build-PST
 dán.
 house
 ‘Ama asked when Kofi BUILT a house.’

³This contradicts Saah & Goodluck (1995), who show that Asante Twi does not exhibit island effects in question formation, relativisation, and topicalisation. However, they only tested cases of \bar{A} -movement from argument positions, the island insensitivity of which is, as Korsah & Murphy (2015) argue, due to Asante Twi having obligatory overt resumption with animates and obligatory covert resumption with inanimates, where resumption can obviate island effects (Borer 1984). Consequently, verb doubling (and *do*-support) in Asante Twi cannot be treated on a par with resumption (i.e. as ‘verbal resumption’) because one would expect it to be insensitive to islands, too, contrary to fact.

- b. *?Dán sí-é na Ama bísá-a se dabén na Kofi
 house build-NMLZ FOC Ama ask-PST COMP when FOC Kofi
 yó-ɔ́é.
 do-PST
 ‘Ama asked when Kofi BUILT A HOUSE.’

(6) *Complex NP island*

- a. *Sí-(é) na mé-ń-té-e atétésém bíará se Kofi
 build-NMLZ FOC 1SG-NEG-hear-PST rumour.PL any COMP Kofi
 á-si dán.
 PRF-build house
 ‘I didn’t hear any rumours that Kofi has BUILT a house.’
- b. *?Dán sí-é na mé-ń-té-e atétésém bíará
 house build-NMLZ FOC 1SG-NEG-hear-PST rumour.PL any
 sé Kofi á-yó
 COMP Kofi PRF-do
 ‘I didn’t hear any rumours that Kofi has BUILT A HOUSE.’

(7) *Subject island*

- a. *Sí-(é) na sé Kofi á-sí dán nó má-a Ama
 build-NMLZ FOC COMP Kofi PRF-build house CD give-PST Ama
 ání gyé-eé.
 eye collect-PST
 ‘That Kofi has BUILT a house made Ama happy.’
- b. *Dán sí-é na sé Kofi á-yó nó má-a Ama ání
 house build-NMLZ FOC COMP Kofi PRF-do CD give Ama eye
 gye-eé.
 collect
 ‘That Kofi has BUILT A HOUSE made Ama happy.’

(8) *Relative clause island*

- a. *Sí-(é) na Ama bísá-a ε-dá áa Kofi sí-i dán.
 build-NMLZ FOC Ama ask-PST day REL Kofi build-PST house
 ‘Ama asked for the day that Kofi BUILT a house.’
- b. *?Dán sí-é na Ama bísá-a εdá áa Kofi yó-ɔ́é.
 house build-NMLZ FOC Ama ask-PST day REL Kofi do-PST
 ‘Ama asked for the day that Kofi BUILT A HOUSE.’

(9) *Adjunct island*

- a. *Sí-(é) na Kofi nóm nsúo efrise ɔ-a-si dan.
 build-NMLZ FOC Kofi drink water because 3.SG-PRF-build house
 ‘Kofi drinks water because he has BUILT a house.’
- b. *?Dán sí-é na Kofi nóm nsúo ésánsé ó-á-yó.
 house build-NMLZ FOC Kofi drink water because 3.SG-PRF-do
 ‘Kofi drinks water because he has BUILT A HOUSE.’

Second, there are a number of TAM constructions and some morphosyntactic processes in Asante Twi that lead to tonal changes on the verb (Boadi 2008, Paster 2010). Among these changes is a process of low tone raising on verbs with underlying L tones. It is triggered in certain syntactic environments, all of which typically involve \bar{A} -movement, like *ex situ* wh-questions (10b) and object focus (10c). It raises all L tones on the verb and attached aspectual (but not tense) affixes. The following examples illustrate this for the L toned verb *di* ‘eat’ and the L toned progressive aspect affix *re-* (10a).

- (10) a. Ama *re-di* bayéré
 Ama PROG-eat yam
 ‘Ama is eating a yam.’
- b. Déén na Ama *ré-dí*?
 what FOC Ama PROG-eat
 ‘What is Ama eating?’
- c. Bayéré na Ama *ré-dí*.
 yam FOC Ama PROG-eat
 ‘It is yam that Ama is eating.’

Korsah & Murphy (2015) argue that L tone raising is not a specific property of the *na*-construction (contra Marfo 2005, Marfo & Bodomo 2005), as one might suspect from (10b, c), because it is also attested in relative clauses (11a) and affects every verb in a long-distance dependency, where only one instance of *na* is present (11b, c). Note that there also is a parallel process of H tone lowering affecting complementizers (HL) that are crossed by an \bar{A} -dependency.

- (11) a. [DP Bayéré nó_i [CP áa Ama *ré-dí* t_i nó]] *da* pónó nó só.
 yam DEF REL Ama PROG-eat CD lie table DEF top
 ‘The yam that Ama is eating is on the table.’

- b. [_{CP} Kofi *nim* [_{CP} sê Esi á-ka [_{CP} sê Ama *di* bayéré.]]]
 Kofi know COMP Esi PRF-say COMP Ama eat yam
 ‘Kofi knows that Esi has said that Ama eats yam.’
- c. [_{CP} Bayéré na Kofi *ním* [_{CP} sɛ Esi á-ká [_{CP} sɛ Ama
 yam FOC Kofi know COMP Esi PRF-say COMP Ama
dí.]]]
 eat
 ‘It is yam that Kofi knows that Esi has said that Ama eats.’

Since tonal changes as reflexes of movement are well-attested cross-linguistically (Lahne 2008, Georgi 2014) and they are associated with verbs and complementizers (*v* and C) in Asante Twi thus corresponding to what are standardly assumed to be phase heads (Chomsky 2000, 2001), Korsah & Murphy (2015) analyse low tone raising on verbs in Asante Twi as a reflex of successive-cyclic \bar{A} -movement through Spec ν P. Crucially, this tonal change also occurs on the lower verb copy or *yɔ* and its aspectual affix in predicate cleft constructions (12).

- (12) a. Dí na Ama *ré-dí* bayéré.
 eat FOC Ama PROG-eat yam
 ‘Ama is EATING yam.’
- b. Bayéré *dí-é* na Ama *ré-yɔ*.
 yam eat-NMLZ FOC Ama PROG-do
 ‘It is eating yam that Ama does.’

If Korsah and Murphy’s analysis is on the right track, this means that these constructions involve an \bar{A} -dependency, too.

What this section has shown is that predicate clefts in Asante Twi exhibit typical \bar{A} -properties and thus lend themselves to an analysis in terms of movement rather than base generation.

2.2. Head movement or remnant movement

A second issue of debate concerning V fronting structures is whether the fronted constituent is a bare head (as proposed by e.g. Koopman 1984, van Riemsdijk 1989, Larson & Lefebvre 1991, Holmberg 1999, Fanselow 2002, Landau 2006, Harbour 2008, Bastos-Gee 2009) or rather a remnant VP or ν P (as argued for by e.g. den Besten & Webelhuth 1990, Grewendorf & Sabel 1994, Koopman 1997, Takano 2000, Abels 2001, Hinterhölzl 2002, Aboh

& Dyakonova 2009, Bondaruk 2012, Müller 2014). Asante Twi shows no evidence for any VP/ ν P evacuating scrambling or licensing movements. This is illustrated in (13) for transitive and in (14) for ditransitive sentences. (13a) and (14a) exemplify the basic word order, whilst (13b) and (14b) show the ungrammaticality of object movement across the verb and across another object. I will thus take it as the most natural assumption to regard the fronted constituent in V fronting as a head.

- (13) a. Kofi á-si dán. b. *Kofi dán á-si.
 Kofi PRF-build house Kofi house PRF-build
 ‘Kofi has built a house.’ ‘Kofi has built a house.’
- (14) a. Kofi ma-a mmofrá nó krataá.
 Kofi give-PST children DET book
 ‘Kofi gave the children a book.’
 b. *Kofi ma-a krataa mmofra no.
 Kofi give-PST book children DET.
 ‘Kofi gave a book to the children.’

2.3. V(P) or ν (P)

The last question to be answered about the syntactic structure of predicate clefts in Asante Twi is about the size of the fronted category. As can be observed, no aspect marking appears on the fronted verb or verb phrase. This also holds for fronted bare verbs that are not nominalised. Overt aspectual marking even leads to ungrammaticality (15).

- (15) (*Á-)Sí-(é) na Kofi á-sí dán.
 (PRF-)build-NMLZ FOC Kofi PRF-build house
 ‘Kofi has BUILT a house.’

Under the assumption that aspect features are encoded on ν , one can conclude that ν is not part of the fronted constituent. Under the alternative assumption that aspect is a separate head, Kandybowicz (2015) argues for it to be above V but below ν in the Asante Twi clause structure.⁴ Fronting of ν (P) would

⁴Further support for Asp beneath ν comes from the tonal movement reflex discussed above where a high tone is inserted when there is \bar{A} -movement to Spec ν P. Low toned aspectual affixes then undergo high tone overwriting while tense affixes do not. As Korsah & Murphy (2015) point out, this follows if Asp is lower in the structure than ν and thus already present when the

then entail fronting of the aspect head predicting aspect marking to occur on the fronted constituent, contrary to fact. Hence, under either assumption, the fronted constituent in Asante Twi must be a V(P).⁵

3. *Yɔ*-insertion is not *yɛ*-insertion

In Asante Twi, there is a default verbal element *yɛ*⁶ which is phonologically similar to *yɔ* and can also be translated as ‘do’ (and ‘make’ and ‘be’, among others). This element has a curious distribution, obligatorily occurring in simple past tense clauses with intransitive verbs (unergative and unaccusative) (16a, b) and monotransitive simple past tense clauses where the object is moved (16c) (examples from Kandybowicz 2015).

- (16) a. Kofi sa-a *(*yɛ*).
 Kofi dance-PST *yɛ*
 ‘Kofi danced.’
- b. Dua no shi-i *(*yɛ*).
 tree DEF burn-PST *yɛ*
 ‘The tree burned.’
- c. Deɛn na Ama di-i *(*yɛ*)?
 what FOC Ama eat-PST *yɛ*
 ‘What did Ama eat?’

Kandybowicz (2015) analyses the occurrence of *yɛ* in these cases as prosodically conditioned. Under the Match theory of syntactic-prosodic constituency correspondence (Selkirk 2011), *yɛ* is inserted late as a Last Resort to avoid a mapping of prosodically vacuous domains from empty syntactic Spell-Out domains, which would violate his proposed constraint against prosodic vacuity. The relevant Spell-Out domain here is AspP, which is, as Kandybowicz (2015)

high tone is inserted. Tense affixes in T, however, enter the derivation too late to be affected by tonal overwriting.

⁵Under the former assumption, this entails that complements of phase heads are allowed to move, contrary to Abels (2003). If Abels were correct, one would expect that the VP as a complement of the phase head *v* was not able to move to SpecCP alone but had to be fronted as part of the larger *v*P or pied-pipe the *v* head. This, however, would leave the ungrammaticality of aspect features in fronted position (15) unaccounted for. The issue does not arise under the latter assumption, where the aspect head prevents VP from being the complement of *v*.

⁶This element is also often pronounced (and written) as a suffix *-ɛ* attached to the long vowel of the verb in the past tense.

argues, the sister of the phase head v . $Y\mathcal{E}$ never occurs if the verb is marked for aspect because in this case the verb has only moved to Asp and hence the AspP is not empty. However, if a verb shows an overt past tense affix it has moved out of AspP to T and, in case it is intransitive, left behind a fully evacuated AspP which triggers $y\mathcal{E}$ -insertion (16a, b). In case the object of a transitive verb with an overt past tense affix has been moved away, too, $y\mathcal{E}$ also occurs, because both the verb and the object have left AspP (16c).

Now let us consider predicate clefts. Since $y\mathcal{O}$ is phonologically and semantically similar to $y\mathcal{E}$, one might be tempted to treat them as variants of one and the same underlying element, which one might call $y\mathcal{E}$, whose insertion is conditioned by prosodic vacuity, as proposed in Kandybowicz (2015). This is, however, not possible. As example (17) shows, $y\mathcal{O}$ occurs in cases where the AspP is not empty but contains an overt aspectual affix. The constraint against prosodic vacuity not being violated here, insertion of $y\mathcal{E}$ is unexpected and unexplained under the approach sketched above.

- (17) Dán sí-é na Kofi ré-yó.
 house build-NMLZ FOC Kofi PROG-do
 ‘Kofi is BUILDING A HOUSE.’

One might argue that the aspect exponent in (17) is only inserted very late, as would be the case in Distributed Morphology, and that prosodically conditioned $y\mathcal{E}$ -insertion happens earlier, at a point where the AspP is still devoid of any phonological material. $Y\mathcal{O}$ might then be regarded as the affix-bearing allomorph of $y\mathcal{E}$. But this would suggest that prosodic domains are created (and prosodic vacuity is determined) before vocabulary insertion into f-morphemes⁷ (roughly, functional heads) has taken place, i.e. before all the phonological material of a Spell-Out domain has been assembled. New phonological material, like the aspect affix, that becomes available only after construction of prosodic structure would have to be integrated into it, uneconomically requiring a second instance of prosodic structure creation.

⁷In DM, the term ‘morpheme’ denotes a syntactic terminal node and its morphosyntactic feature bundle, not the phonological exponent of that node. Terminals for which there is no free choice as to Vocabulary Insertion, i.e. whose phonological realisation is solely determined by their morphosyntactic content are f-morphemes. L-morphemes, on the other hand, allow for a choice, i.e. they may be filled by Vocabulary Items that denote language specific concepts. The distinction is roughly that between functional and lexical heads (cf. Halle 1992, Embick 1997, Marantz 1997, Harley & Noyer 1998, 1999).

However, even if one adopts the Late Insertion account, this cannot be the whole story because there are instances of $\gamma\text{ɔ}$ in Spell-Out domains that contain more than just affixal material. Consider the grammatical sentence in (18), which combines VP fronting with simple past tense, where Asp is empty and the verb moves to T (Kandybowicz 2015), and exhibits both $\gamma\epsilon$ and $\gamma\text{ɔ}$.

- (18) Dán sí-e na Kofi $\gamma\text{ɔ}$ - ɔ $\gamma\epsilon$.
 house build-NMLZ FOC Kofi do-PST $\gamma\epsilon$
 ‘Kofi BUILT A HOUSE.’

According to an analysis that conflates $\gamma\epsilon$ and $\gamma\text{ɔ}$, both instances of the default verbal element should be triggered by the need to avoid prosodically empty Spell-Out domains. $\gamma\epsilon$ is inserted upon Spell-Out of the first phase domain that is sent to PF, which is the sister of ν , i.e. the empty AspP. Under standard assumptions about phases, the next domain that is spelled out is the TP which is the domain of the next phase head C. This domain, however, is not empty in the above example as it contains the subject which, as an l-morpheme, crucially must have undergone vocabulary insertion before prosodic domain construction (otherwise every syntactic domain would map onto an empty prosodic domain reducing the whole approach to absurdity). Nevertheless, $\gamma\text{ɔ}$ is inserted, although this, crucially, does not happen to avoid a prosodically empty domain but rather to provide a host for the past tense affix. I thereby conclude that Kandybowicz (2015) conditions for $\gamma\epsilon$ -insertion are different from those of the phonologically and semantically similar element $\gamma\text{ɔ}$ and that they therefore cannot be the same element.

Additionally, the asymmetric pattern of verb doubling with V fronting but *do*-support with VP fronting can also be found in Gã (and some other Kwa languages), which does not show instances of *do*-support (here realised by *feé* ‘do’) as a means to avoid prosodic vacuity.

- (19) a. Kofi há gbékébíí ϵ shiká.
 Kofi give children DEF money
 ‘Kofi gave the children some money.’
 b. Kofi báa-jó (*feé).
 Kofi FUT-dance do
 ‘Kofi will dance.’

- c. Há-(mɔ) (ni) Kofi há/*feé gbékébíí ɛ shiká.
 give-NMLZ FOC Kofi give/do children DEF money
 ‘Kofi GAVE the children some money.’
- d. Gbékébíí ɛ shiká há-mɔ (ni) Kofi *há/feé.
 children DEF money give-NMLZ FOC Kofi give/do
 ‘Kofi GAVE THE CHILDREN SOME MONEY.’

Example (19a) provides a regular declarative sentence with a ditransitive verb while (19b) shows that there is no *do*-support of any kind when a verb has moved to T leaving an empty AspP/*v*P behind. Examples (19c, d) exemplify a V fronting and VP fronting structure, respectively. If the occurrence of *feé* in VP fronting (19d) were due to a prosodic constraint against empty AspP/*v*P, then it should also occur in (19b), contrary to fact. In Gã, *do*-support with VP fronting in the asymmetric pattern of verb doubling therefore cannot be governed by such a constraint.

This provides some further support for treating the asymmetric pattern in Asante Twi as a real and genuine phenomenon rather than an epiphenomenon resulting from the interaction of prosodically conditioned *do*-support and the AspP-emptying property of VP fronting.

4. An ordering analysis

4.1. Preliminaries

Under the Copy Theory of Movement, where movement is decomposed into the suboperations Copy and Merge and leaves a copy of the moved element in its base position (Chomsky 1993, 1995), verb doubling can be easily accounted for as being a consequence of Spell-Out of more than one copy of a moved element (Abels 2001, Nunes 2004). However, in the standard cases, only one link/copy in a movement chain is pronounced, namely the head of that chain, while the others are left unpronounced. Several attempts have been made to account for this (Brody 1995, Bobaljik 1995, Groat & O’Neill 1996, Pesetsky 1997, 1998), the most recent one by Nunes (2004). He proposes an operation of Chain Reduction that applies at PF and (in the standard case) deletes lower elements of a chain under phonological identity with the highest one. I will adopt his approach in the following insofar as I assume an operation Chain Reduction that applies to movement chains at PF and deletes lower copies. However, I

reject the identity requirement and the economy conditions assumed for it. A chain consists of positions that are related by syntactic movement (chain links). Chain Reduction then simply deletes the elements that occupy the lower positions (copies) irrespective of whether they are identical to or a proper subset of the copy in the highest chain link.⁸

What is then the reason that the verb is spelled out two times in the predicate clefts above? The answer is that the verb actually moves twice in those constructions thereby creating two distinct parallel chains whose respective heads are spelled out while their shared tail is deleted (Aboh 2006, Collins & Essizewa 2007, Chomsky 2008, Kandybowicz 2008, Aboh & Dyakonova 2009). One movement is \bar{A} -movement into SpecCP (either as a bare head or as part of the whole VP) in order to satisfy the focus feature on C and the other is head movement to v and/or T.

As mentioned above, V fronting in Asante Twi seems to involve movement of a bare head rather than remnant movement. This kind of \bar{A} -head movement into a specifier position has first been suggested by Koopman (1984) and, as Vicente (2007, 2009) shows, is not in conflict with current ideas about how movement works but rather is their logical extension. Since it shows all the characteristics of phrasal \bar{A} -movement, I assume that Head-to-Spec Movement (HSM) works just like the former in that it is triggered by the same features and has to obey the standard constraints on movement (Minimal Link Condition, Phase Impenetrability Condition).

With regard to Head-to-Head Movement (HHM), on the other hand, I diverge from Vicente's proposal. Going back to a suggestion by Chomsky (1995), many researchers have proposed accounts treating HHM as a PF operation rather than a syntactic one (cf. Brody 2000, Hale & Keyser 2002, Bury 2003, Harley 2004, Platzack 2013) mainly because it does not seem to have an effect on interpretation,⁹ but also because it poses some technical problems for syntactic theory (e.g. it violates the Extension condition). I will adopt their view of HHM

⁸ Actually, for Nunes (2004) identity of copies must be restricted to identity of their phonological features ignoring their morphosyntactic ones. Otherwise, he would have to treat lower copies with unvalued morphosyntactic features, such as e.g. Case, as distinct from higher copies with the respective valued versions of these features. The way Nunes' system is set up, morphosyntactically, lower copies are necessarily (proper) subsets of higher copies. This property is used in a Late Insertion approach to resolution of movement chains by Muñoz Pérez (2015) in order to overcome several flaws of Nunes' original proposal.

⁹ Though see Lechner (2001, 2004, 2007) and Roberts (2010) for arguments that at least in some cases head movement affects interpretation at LF.

and further assume that PF-movement does not leave any copies (or traces) (Boeckx & Stjepanović 2001, Sauerland & Elbourne 2002).

4.2. The order of operations at PF

As a consequence, the two verbal movements now crucially happen on two derivationally separate levels, focus movement in (narrow) syntax and *V-to- ν /T* movement at PF. Chain Reduction, as already mentioned, also applies at the level of PF. In the spirit of recent work concerned with timing of elementary operations (Müller 2009, Arregi & Nevins 2012, Georgi 2014, Murphy & Puškar 2015, Puškar 2015, Assmann et al. to appear), I propose that there is an order between these two PF operations that is invariable within a language but may vary across languages. This order gives rise to either the symmetric or asymmetric pattern of verb doubling in the following way. In VP fronting, if HHM applies before CR, V head-moves out of the lower VP copy thereby leaving the lower link of the VP-movement chain. Subsequent CR, which deletes the element in that position affects the remnant VP but it crucially cannot affect the V. Since CR only applies to the elements that occupy the lower positions in a movement chain and the V head has been moved out of this position to ν /T prior to application of CR, it evades deletion. Hence, CR counterbleeds HHM in this order as CR would have deleted the element undergoing HHM had it applied earlier. Both the lower V copy and the one in the VP copy in SpecCP survive, which results in verb doubling. If the reverse order holds at PF, CR applies to the lower chain link of the VP chain first. The VP copy occupying this position is deleted and with it its constituents including the V head. Subsequent HHM cannot apply (or can only apply to ν) since there is no V anymore. Therefore, CR bleeds HHM which gives rise to *do* insertion into ν /T in order to provide a host for Spell-Out of the aspect/tense affix in these functional heads. In V fronting, however, CR cannot apply to the lowest V copy even when it applies before HHM. V fronting involves \bar{A} -head movement of V to some specifier position, a movement step that cannot create a chain. If it did, this chain would violate the Chain Uniformity Condition (Chomsky 1995, van Craenenbroek 2010): Its lower link's phrase structure status would be minimal but not maximal, that of its upper link would be both minimal and maximal while the Chain Uniformity Condition demands that a chain be uniform with regard to phrase structure status. If the movement created a chain, it would be illicit. However, since such movement exists (Koopman 1984,

Landau 2006, Vicente 2007, 2009), it cannot create a chain. Because there is no chain in V fronting, Chain Reduction cannot apply and HHM may move V to ν /T unimpededly, which gives rise to verb doubling under either order. An overview of the interactions between the type of fronting and the order of operations at PF is given in the table in (20) with a language exhibiting each order.

(20) *Interaction of fronting type with order of PF operations*

	V fronting	VP fronting	
HHM >> CR	verb doubling	verb doubling	(Hebrew ¹⁰)
CR >> HHM	verb doubling	<i>do</i> -support	(Asante Twi)

In what follows, the relevant derivations will be discussed in more detail in a phase based model of syntax that takes ν and C to be the only phase heads (Saddy 1991, Chomsky 2001, van Urk & Richards 2015). I will adopt the weak version of the Phase Impenetrability Condition (Chomsky 2001) where the domain of a phase is sent off to PF and thus becomes unavailable to further syntactic operations upon merge of the next higher phase head (i.e. C for the ν P phase). This means that the VP is transferred to PF as soon as the C head is merged with the TP. In the case of the final CP, the domain is sent off upon completion of the phase. The head and edge of the CP phase are passed on to PF only after that. Due to the Phase Impenetrability Condition, in a phase based model of syntax, elements moving higher up in the clause need to do so successive-cyclically, passing through the respective phase heads' specifiers. A focussed V/VP thus needs to first move to Spec ν P where it leaves a copy, because upon merge of the C head, VP as the domain of ν P is sent off to PF and becomes inaccessible for further syntactic movements.

4.3. CR applies before HHM: asymmetric verb doubling

In this subsection, I will be concerned with the order CR before HHM considering VP fronting first and V fronting after it. This order derives the asymmetric pattern as found in Asante Twi. The mechanics of the system as

¹⁰For reasons of exposition and understandability, I will treat the moved constituent in Hebrew as V or VP although Landau (2006) convincingly argues that it is actually ν and ν P. As will be discussed in section 5, the proposed system can be extended to ν/ν P movement making the same predictions as for V/VP movement.

well as some of its peculiarities will become clear throughout the following discussion. Linearisation applies after syntax, hence the given tree structures do not necessarily reflect surface linearity. The next subsection will subsequently consider the reverse order.

VP fronting In the derivation of VP fronting, the VP ultimately has to arrive in SpecCP, a position which will only come into existence later. It is therefore first copied and moved to Spec ν P in the syntactic module due to the PIC in order to escape the domain of the first phase head ν . When C is merged, this domain (i.e. the lower VP) is passed on to PF while the VP in Spec ν P is copied and moved to SpecCP in the syntax. At PF, CR applies vacuously because only a trivial chain (i.e. one chain link) is present at the moment and HHM applies vacuously because there is no head that could serve as the target for HHM of V. Upon completion of the CP phase, the TP is transferred to PF, which includes the VP copy in Spec ν P and the target heads ν and T for HHM (21a). The original VP domain of ν is still present at PF. The third VP copy in SpecCP is not visible to CR at this point because it has not been transferred to PF yet. Since the VP copy in its base position occupies the lower link in the (PF visible) chain, it is deleted (indicated by striking out). The subject copy in Spec ν P, by virtue of being the lower link in the subject movement chain, is deleted by CR, too. Subsequent HHM of V to ν and T is impossible because the lower V copy, as a constituent of the lower VP, was deleted with it (21a). Only HHM of ν to T can take place (solid lines). Recall that HHM does not leave any copies (indicated by parenthesis around the element in its position prior to movement). Next, the edge and head of the CP phase are transferred to PF containing the third VP chain link. CR deletes the VP copy in Spec ν P which is now the lower link of the VP chain (21b). As there are no new target heads for HHM of the V- ν -T complex in this cycle, subsequent HHM applies vacuously.

(21) CR ① >> HHM ② in VP fronting: Do-support

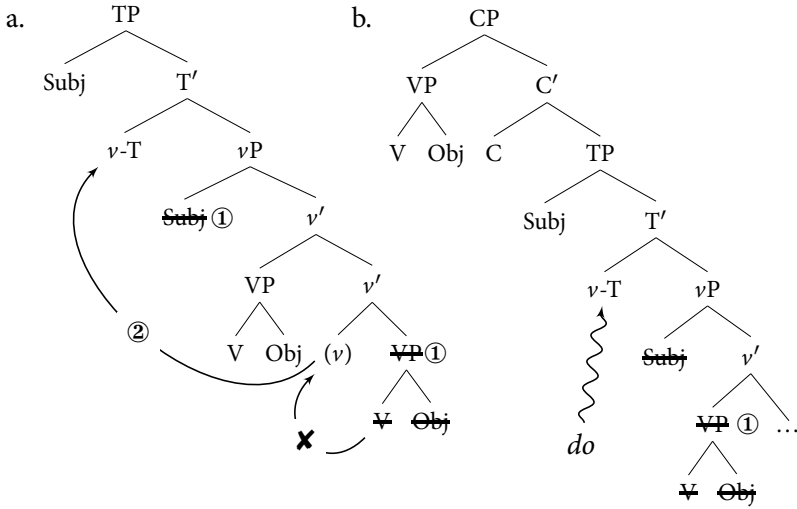

In order to enable Spell-Out of the aspect and tense affixes in v and T, a dummy verb *do* is inserted as a Last Resort. Hence, CR applying before HHM leads to *do*-support in VP fronting because the V head fails to evade deletion as part of the lower VP copy.

V fronting In the case of V fronting, on its way to SpecCP, V is first moved to SpecvP to remain syntactically available for a later stage of the derivation. Since this movement is \bar{A} -head movement in the syntactic module, CR cannot bleed HHM even though it applies before it. This is due to the nature of \bar{A} -head movement: Its first step relates a copy of a head in its base position, where it is minimal but not maximal, with a copy of that head in a specifier position, where it is both minimal and maximal. This movement does not create a chain since it would violate the Chain Uniformity Condition which demands that a chain be uniform with regard to phrase structure status. Therefore, when the V head is copied and moved to SpecvP in syntax, no chain is established between the two V copies. Upon merge of the phase head C, VP is sent off to PF, where CR and HHM apply vacuously as mentioned above in the case of VP fronting. Next, V in SpecvP is copied again and moved to SpecCP. Note that this movement step, in contrast to the first one, does create a chain since both the V copy in SpecvP and that in SpecCP are minimal and maximal, i.e. are

uniform with regard to their phrase structure status. The CP phase is thus completed and its domain TP is sent off to PF. CR applies and does not delete anything except the lower copy of the subject (22a). Importantly, both V copies that are present at PF at this point are not linked to each other by a chain. Consequently, CR cannot delete the lower one, which is not part of any chain, because it only applies to chains, whereas it cannot delete the upper one, which is part of a chain, since the higher chain link is not visible to PF yet. Therefore, HHM can move the lowest V copy to v and on further to T.

(22) CR ① >> HHM ② in V fronting: Verb doubling

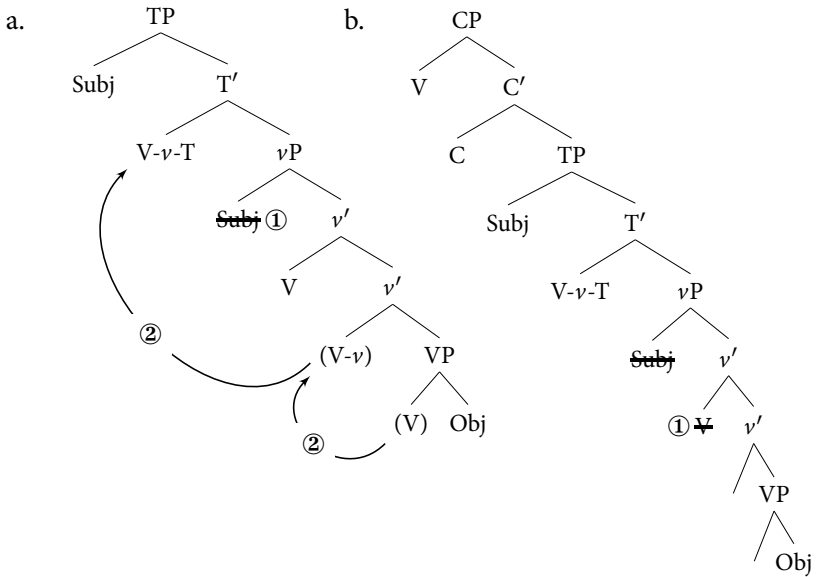

In the next step, when the third copy of V in SpecCP reaches PF, CR applies to the chain between it and the V copy in SpecvP, deleting the latter. HHM applies vacuously and the resulting structure contains two V copies, one in SpecCP and the other as part of the complex V- v -T head (22b). Hence, CR >> HHM leads to *do*-support in VP fronting because V is deleted as part of the lower VP copy before it can move to v , but results in verb doubling in V fronting because V is protected from deletion by the peculiar property of \bar{A} -head movement to not

from a chain in the first movement step. CR >> HHM thus derives a pattern of verb doubling which is exactly the asymmetric pattern found in Asante Twi.¹¹

4.4. HHM applies before CR: symmetric verb doubling

In this subsection, I will be concerned with the order HHM before CR and its consequences first with regard to VP fronting and second with regard to V fronting. As will be shown, the order leads to a symmetric pattern of verb doubling as found in Hebrew and actually most other languages that allow verb doubling as well as V and VP fronting. Since nothing of interest to the present issue happens within the VP step of the derivations, it will be omitted from the following discussions.

VP fronting When the domain of CP, which contains two copies of VP in one movement chain, is passed on to PF, HHM applies before CR and moves V to *v* and the resulting complex head to T. Recall that HHM does not leave any copies so there is no V anymore in the VP copy constituting the lower link of the movement chain. Subsequent CR applies to the chain that contains the VP copy in its base position and the VP copy in SpecvP. Since the VP copy in the base position occupies the lower link in the (PF visible) chain and is a subset of the VP copy in the higher chain link, it is deleted. The subject copy in SpecvP is

¹¹Kandybowicz (2015) argues that the verb in Asante Twi only moves on to T when the Asp head (here *v*) has a null realisation, otherwise it stops in *v*. The structures given here summarise over both possibilities always showing HHM of V-*v* to T. For sentences where both aspect in *v* and tense in T are overtly expressed (i) he argues that the subject stays in its base position.

- (i) Ná Kofi á-si dán.
 PST Kofi PRF-build house.
 ‘Kofi had built a house.’

As predicted by the analysis, these sentence show the same pattern like those that only express either tense or aspect overtly. V fronting triggers verb doubling (iia) while VP fronting requires *do*-support (iib).

- (ii) a. Sí-(é) na Kofi á-sí/*á-yó dán.
 build-NMLZ FOC Kofi PRF-build/PRF-do house
 ‘Kofi has BUILT a house.’
 b. Dán sí-é na Kofi *á-sí/á-yó
 house build-NMLZ FOC Kofi PRF-build/PRF-do
 ‘Kofi has BUILT A HOUSE.’

also deleted (23a). When the rest of the CP phase arrives at PF, HHM applies vacuously as there are no new target heads for HHM of the V-*v*-T complex in this cycle. CR, however, applies to the chain containing one VP copy in Spec*v*P and one in SpecCP deleting the former (23b).

(23) HHM ① >> CR ② in VP fronting: Verb doubling

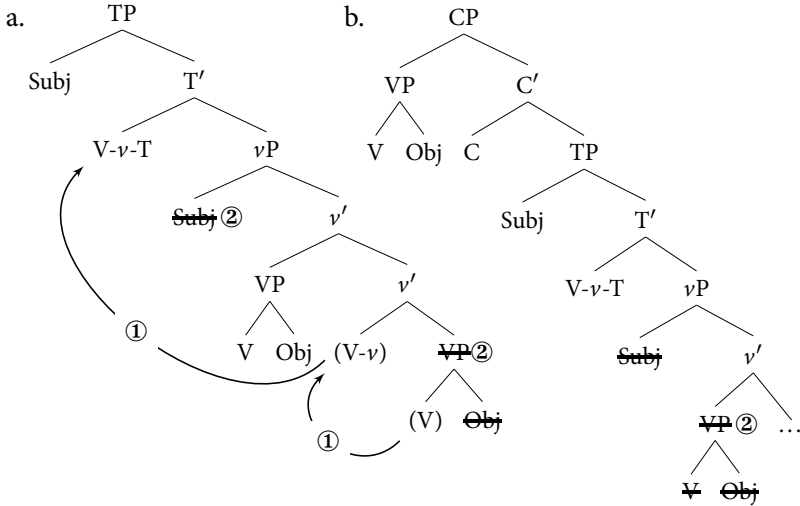

The resulting structure contains two copies of the V head, one as the head of the VP copy in SpecCP, and the other as part of the complex V-*v*-T head. Thus, contrary to the reverse order, HHM >> CR leads to verb doubling rather than *do*-support in VP fronting because the V head can move to *v* before the lower VP copy is deleted.

V fronting In V fronting, where the verbal head undergoes \bar{A} -head movement in the syntactic module, CR cannot delete the lower V copy for two reasons. First, due to Chain Uniformity there is no chain between the V copy in its base position and the V copy in Spec*v*P. Second, HHM applies before CR. Hence, when the V copy in Spec*v*P is copied again, moved to SpecCP, and the TP is sent off to PF, first, HHM applies moving the lowest V copy to *v* and on to T. Next, CR applies and does not delete anything except for the lower copy of the subject (24a).¹² Upon transfer of the CP's edge and head, the higher

¹²Note that even if there were a chain between the two V copies, CR applying after HHM could still not delete the lower one. This is due to chain links being defined as positions in the

link of the V chain in SpecCP becomes available. After vacuous application of HHM, CR deletes the lower V copy of the chain in SpecvP. The resulting structures in (23) and (24) each contain two copies of the verb, one as part of the complex V-*v*-T head and another in SpecCP either as part of a fronted VP or as a bare head. The order HHM before CR thus derives the symmetric pattern of verb doubling with both V and VP fronting as found in Hebrew and various other verb doubling languages. It does so by moving out of the lower VP in VP fronting before it gets deleted. The lower V copy in V fronting is protected by the above-mentioned idiosyncrasy of \bar{A} -head movement.

(24) HHM ① >> CR ② in V fronting: Verb doubling

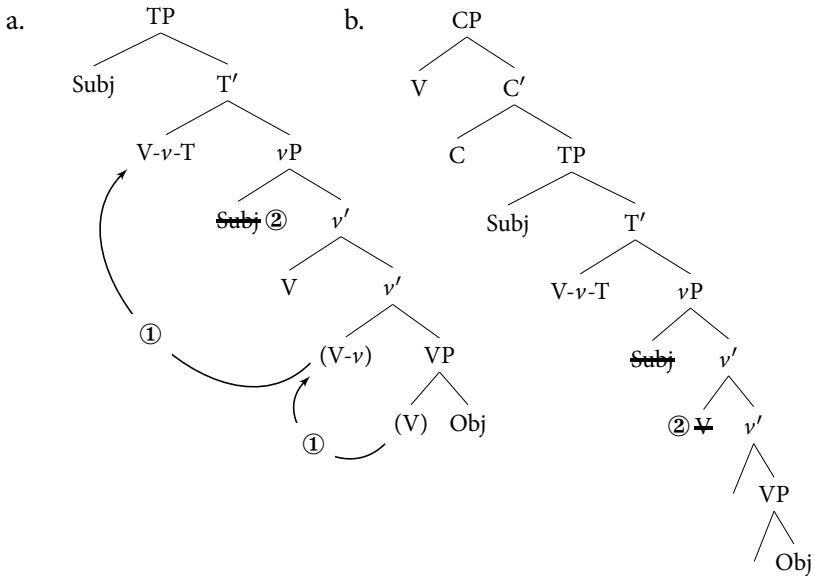

4.5. Interim summary and predictions

As the preceding sections showed, a simple ordering of Chain Reduction and Head-to-Head Movement at PF derives the two patterns of verb doubling manifested by Hebrew on the one side and Asante Twi on the other. If HHM

structure that are related by movement. If HHM moves the lower V out of the position that is the lower chain link (i.e. sister of Obj/daughter of VP), CR will only detect one copy in the chain (the one in SpecvP) and deletion will not be triggered as it is not necessary.

applies before CR, establishing a counterbleeding relation as in Hebrew, the verbal head V evades deletion by CR because it moves away before the element in the relevant chain link can be deleted. The result is verb doubling. In Asante Twi, CR applies before HHM, establishing a bleeding relation. V is deleted before it can be moved elsewhere, resulting in *do*-support unless there is no movement chain to begin with. This is the case for the first step of \bar{A} -head movement in V fronting where V survives CR by virtue of not being part of a chain. Subsequent HHM can apply to V and verb doubling results. The asymmetric pattern of verb doubling in Asante Twi therefore is a consequence of the language's order of operations at PF and the idiosyncratic property of \bar{A} -head movement to not form uniform chains in the first movement step.

Crucially, the reverse Asante Twi pattern, namely verb doubling in VP but *do*-support in V fronting is excluded by two independent principles of this proposal. First, due to the nature of \bar{A} -head movement in V fronting, it is not possible for CR to delete the V in its base position. Therefore, whenever the verb itself has been moved in the syntax there will be two copies of it in the structure, one of which will be used to host inflectional affixes, obviating the need for any *do*-support. Second, even if the verb formed a chain with its copy in V fronting, CR would have to apply before HHM to derive *do*-support. However, this order of operations also leads to *do*-support in VP fronting deriving a language that shows *do*-support in both kinds of verbal fronting. Such a language is German, which uses remnant VP movement instead of \bar{A} -head movement (den Besten & Webelhuth 1990, Grewendorf & Sabel 1994, Koopman 1997, Hinterhölzl 2002, Müller 2014) to front a verb without its arguments (25). Here, the lower verb copy within the evacuated VP remnant is part of the VP chain and may thus be affected by CR before it undergoes HHM to *v*/T.

- (25) [_{VP} t₁ Lesen]₂ tut sie [_{DP} Bücher]₁ gern t₂.
 read.INF do.3SG she books gladly
 'She likes to READ books (as opposed to e.g. writing them).'

Before turning to remnant movement in section 6, the next section will introduce a modification of the present account that will allow it to be extended to cases of predicate fronting that involve V-*v*/*v*P instead of V/VP.

5. Extending the approach to V-*v*/vP movement: Entire phases at PF

As it stands, the proposed account derives the correct patterns for V/VP movement. However, as Landau (2006) convincingly argues, the constituent that is fronted in Hebrew verbal topicalisation is actually not V/VP but rather V-*v*/vP. Vicente (2007, 2009) shows that the same holds for Spanish predicate clefts. Both languages exhibit verb doubling in V fronting as well as VP fronting. This poses a problem for the ordering account: Copies are created only when an element is moved in the syntax but this element cannot be a complex V-*v* head because complex heads are created by HHM, which applies only after syntax at PF. If it is only the *v* that moves and leaves copies in the syntax, it remains puzzling why we get two tokens of the lexical verb.

In order to integrate V-*v* doubling into the ordering account, it is necessary to allow the output of HHM of V to *v* to serve as the input to syntax such that the whole complex head can be copied and moved. This is only possible if the entire phase is sent off to PF with its head and edge but not its domain accessible to further syntactic operations as argued for by Fox & Pesetsky (2003, 2005), Svenonius (2004, 2005), Fowlie (2010), Richards (2011) and Aelbrecht (2012). Under this premise, the entire phase would be transferred to PF upon completion. PF operations would apply and potentially alter the edge and head, e.g. creating a complex head. This altered edge/head could then be affected by further syntactic operations, e.g. movement. Crucially, though, V/VP movement and the effects that an order of PF operations has on it remain unaffected by this modification. The interaction of the different orders of PF operations with V-*v*/vP movement is the same as with V/VP movement: HHM before CR gives rise to symmetric verb doubling while the reverse order CR before HHM results in asymmetric verb doubling. The respective derivations will be discussed in detail in the following subsections.

5.1. HHM applies before CR: symmetric verb doubling

In this subsection, I will discuss the order HHM before CR first for the case of V fronting of a complex V-*v* head and thereafter for the case of VP fronting of a vP.

V fronting In V fronting of V-*v*, apart from raising of the subject to SpecTP no syntactic movement takes place before C enters the derivation. When C is

merged, the entire ν P phase is sent to PF, where HHM moves V to ν creating the complex head V- ν (recall that HHM does not leave any copies). CR applies vacuously since the higher link of the subject movement chain is not yet visible at PF (26a). Next, the newly formed complex V- ν head is copied and moved to SpecCP. Since this movement is \bar{A} -head movement, it does not create a chain. The whole thus completed CP is transferred to PF, where first further HHM applies to the lower copy of the complex head moving and adjoining it to T. As there are no other movement chains, subsequent CR only applies to the subject chain deleting the lower copy and the derivation ends (26b).

(26) HHM ① \gg CR ② in V fronting of V- ν : Verb doubling

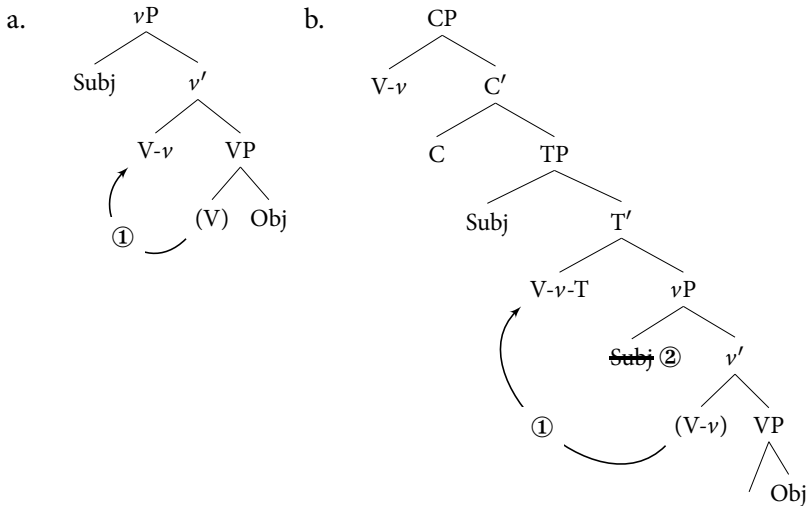

VP fronting In VP fronting where the fronted constituent is a ν P, the first syntactic movement is that of the subject to SpecTP creating a chain. Afterwards, the C head is merged and triggers transfer of the entire ν P phase to PF where V head-moves to ν first. Subsequent CR applies vacuously (27a). Next, the whole ν P still containing the lower link of the subject chain is copied and moved to SpecCP. Then the CP phase is sent to PF and HHM applies first moving the complex V- ν head to T. Subsequent CR is now faced with a remnant movement configuration: The subject has been extracted out of the ν P, which in turn has been moved above the subjects new position. Remnant movement is a perennial problem for the Copy Theory of Movement (Gärtner 1998) because

the copy of the extracted element contained in the higher copy of the remnant is no longer c-commanded by a higher copy of itself. It is, hence, not part of a chain and expected to evade deletion, which would result in it being phonetically realised, contrary to fact. Nunes (2004) proposes a solution that I will also adopt here. Chain links refer to positions in the tree filled by syntactic objects and Chain Reduction, upon inspecting a chain, determines which of its links are c-commanded by another link. It then proceeds to delete the elements in those links and identical elements in identical positions elsewhere in the tree. Therefore, when CR applies to the subject chain and identifies the lower link for deletion, i.e. the subject copy that is the sister of v' and the daughter of vP , it not only deletes that copy but the identical copy in the identical configuration (sister of v' and daughter of vP) in the higher vP as well. Application of CR to the vP chain leads to deletion of the lower vP copy (27b).

(27) *HHM* ① \gg *CR* ② in *VP* fronting of vP : *Verb doubling*

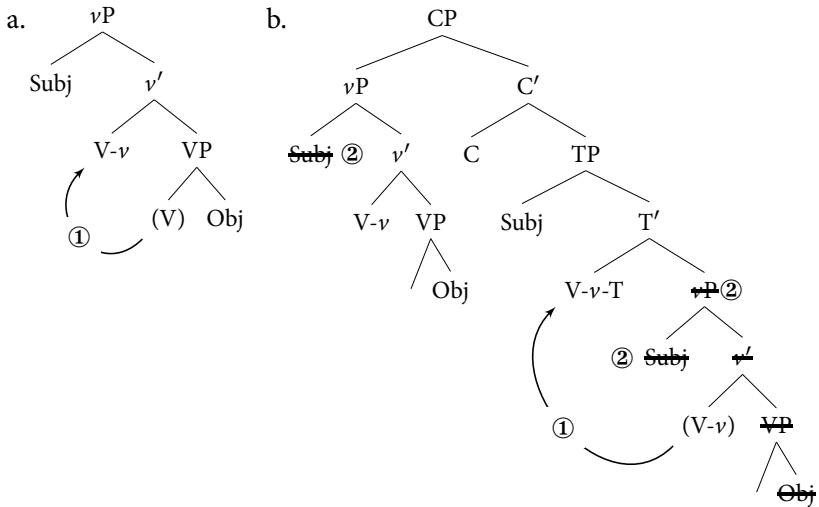

The resulting structures in (26) and (27) both contain two copies of the $V-v$ head, which manifests itself as verb doubling on the surface. Hence, the order *HHM* \gg *CR* leads to verb doubling in both V and VP fronting no matter whether the fronted constituent is V/VP or $V-v/vP$. Note, however, that movement of $V-v$ to T is a necessary condition in order for verb doubling to occur in (27). If the lower copy of the complex head did not move to T ,

it would be deleted as part of the lower ν P leaving only the copy in Spec ν P. In VP fronting where it is VP rather than the ν P that moves, it is sufficient for the V head to move to ν in order to evade deletion. This directly leads to the prediction that languages that do not have verb-to-T movement but nonetheless show fronting of ν P do not exhibit verb doubling.

5.2. CR applies before HHM: asymmetric verb doubling

This subsection considers the order CR before HHM. I will treat V fronting of a complex V- ν head first followed by VP fronting of a ν P.

V fronting In V fronting, after merge of C the ν P phase is transferred to PF. As the higher copy of the subject chain is not visible yet and there are no other chains, CR applies vacuously. Subsequent HHM moves V to ν creating V- ν (28a). In syntax, this complex head \bar{A} -head moves to SpecCP. Recall that this type of movement does not create a chain. Upon completion of CP, the whole phase is sent off to PF where, first, CR applies to the one existent chain deleting the lower copy of the subject followed by HHM of V- ν to T (if the language has V to T movement) (28b). The resulting structure contains two copies of the complex V- ν head resulting in verb doubling on the surface, as was the case for V movement under the same order.

(28) CR ① \gg HHM ② in V fronting of V- ν : Verb doubling

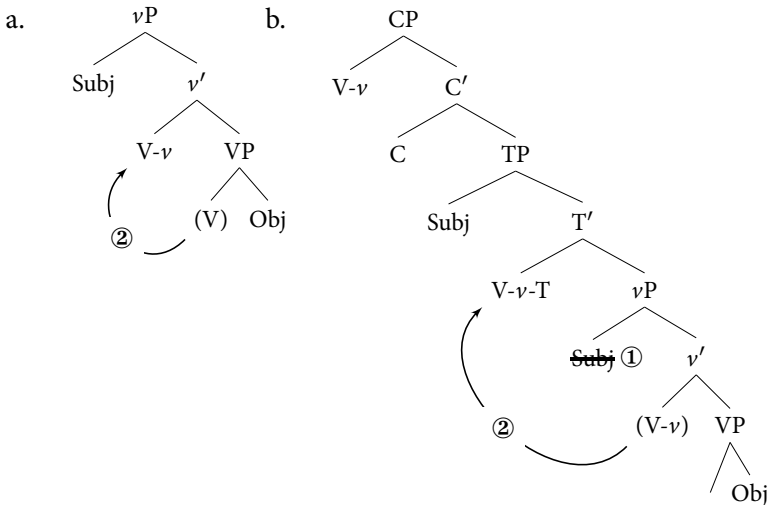

VP fronting In VP fronting there is *do*-support. The first movement that takes place is that of the subject to SpecTP. Upon merge of C, the *v*P phase is sent to PF where CR applies vacuously (since the higher subject copy is not visible yet) and subsequent HHM moves V to *v* (29a). Next, the *v*P is \bar{A} -moved to SpecCP and the CP is transferred to PF. CR applies first and deletes the lower copy of the subject chain and the one in the higher copy of *v*P because it is in an identical position. Crucially, the lower copy of the *v*P chain is also deleted before HHM can move the complex head V-*v* out of it to T. Consequently, HHM applies vacuously. Then, in order to enable Spell-Out of the affix in T, *do* is inserted as a Last Resort (29b).

(29) CR ① \gg HHM ② in VP fronting of *v*P: *Do* support

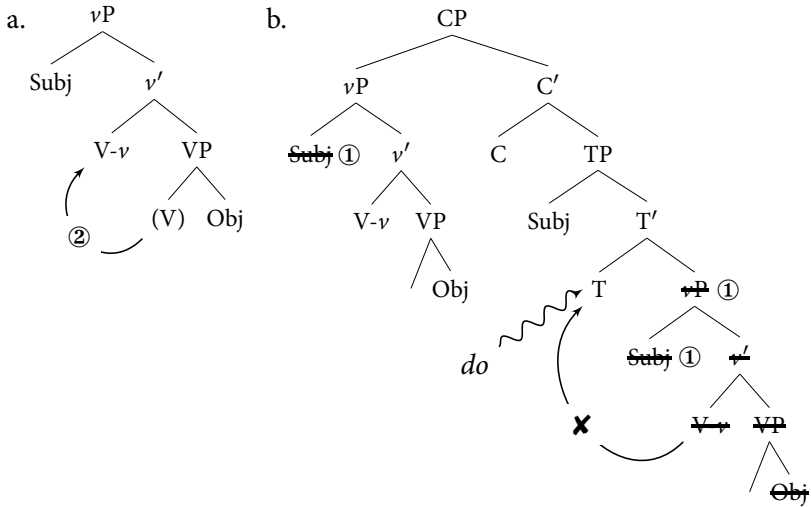

As with V/VP movement, the order CR \gg HHM derives an asymmetric pattern of verb doubling with \bar{V} -*v*/*v*P movement, too. Again, verb doubling only occurs in V fronting due to \bar{A} -head movement not creating a uniform chain in the first step while *do*-support is triggered in VP fronting contexts.

5.3. Interim summary

As shown in the previous sections, assuming that the entire phase is sent off to PF allows us to derive from the same orders of PF operations the same patterns of verb doubling for languages like Hebrew and Spanish where the fronted

constituent is $V-\nu/\nu P$ instead of V/VP . $HHM \gg CR$ gives rise to the symmetric pattern and $CR \gg HHM$ to the asymmetric pattern. Nothing changes under this assumption for the V/VP languages: They contain two copies of the moving V/VP in the νP phase already and at PF, HHM may save the V head by moving it to ν prior to deletion of VP under the order $HHM \gg CR$ resulting in verb doubling. If CR applies before HHM , the V inside the lower VP copy will be deleted before it can move to ν , resulting in *do*-support. In cases of V fronting, under both orders CR cannot apply to the lower V copy since it is not part of a (uniform) chain anyway giving rise to verb doubling. Hence, for languages that move V/VP like Asante Twi, the assumption that the entire phase is transferred to PF does not affect the relation between order of PF operations and the resulting verb doubling pattern.

6. Remnant $VP/\nu P$ movement

In this section, I will discuss languages that make use of remnant VP or νP movement instead of \bar{A} -head movement to front a single verb without its arguments. It is shown that due to the absence of \bar{A} -head movement only symmetrical patterns arise. For such languages, the order $CR \gg HHM$ results in *do*-support in both VP fronting and V fronting contrary to languages that employ \bar{A} -head movement where V fronting consistently leads to verb doubling. The reverse order $HHM \gg CR$ gives rise to symmetric verb doubling, just as it did for languages with \bar{A} -head movement.

6.1. CR applies before HHM : *do*-support

As already hinted at in the table in (3) above, there are languages like German that exhibit the third logically possible pattern, namely *do*-support in both V and VP fronting as exemplified by the verbal topicalisations in (30a, b) respectively.

- (30) a. *Lesen tut sie Bücher gern. (Aber schreiben nicht.)*
 read.INF do.3SG she books gladly (but write.INF not)
 ‘She likes to READ books. But she doesn’t like to write them.’
- b. *Bücher lesen tut sie gern.*
 books read.INF do.3SG she gladly
 ‘She likes to READ BOOKS.’

In the present approach, *do*-support in VP fronting is a consequence of the order CR >> HHM at PF. Therefore, the derivation of the German example (30b) would proceed as illustrated in (29) in section 5.2. However, German V fronting cannot involve \bar{A} -head movement of V because this should result in verb doubling, contrary to fact, due to the special properties of the first step of that movement. Nevertheless, if German employed some other kind of movement that did not protect V from deletion by early CR, *do*-support would be the expected result. It has indeed been argued that German V fronting involves remnant VP movement (den Besten & Webelhuth 1990, Grewendorf & Sabel 1994, Koopman 1997, Hinterhölzl 2002, Müller 1998, 2014) rather than \bar{A} -head movement. Remnant VP movement under the order CR >> HHM gives rise to *do*-support in the following way.

In order to create a remnant VP, the object has to scramble out of it. There is considerable disagreement in the field about what kind of movement (if at all) scrambling actually is and which position(s) it targets (see Karimi 2005: for a recent overview). For the sake of explicitness, I will follow Hiraiwa (2010) who derives the condition in (31) from phase theory.

(31) *Condition on remnant movement* (Hiraiwa 2010: 135)

A remnant movement cannot apply when the operation that extracts *x* from the remnant is a movement to the edge of a phase.

Since German allows remnant movement it follows from (31) that the remnant creating movement does not target a phase edge like Spec ν P or SpecCP. In the case of remnant VP movement, I thus conclude that the object scrambles to SpecTP. This movement does not violate the weak version of the PIC that is presumed in this paper. When T is merged, the domain VP of the phase head *v* and thus the object is still accessible for syntactic operations because the next phase head C has not yet entered the tree. Turning back to the derivation, the object cannot first move to SpecTP followed by movement of VP to Spec ν P as the latter step would violate the Extension Condition (Chomsky 1993, 1995). Therefore, first, the VP has to move to Spec ν P in order to be accessible for movement to SpecCP later. Then, T is merged and attracts the subject and the object into its specifier. Upon merge of C, the entire ν P phase is then sent off to PF where CR deletes the lower VP copy. Subsequent HHM cannot move V to *v* since there is no V in *v*'s c-command domain anymore (32a). In narrow syntax, the VP moves into the topic position in SpecCP. The complete CP is then

transferred to PF. CR applies and deletes the lower subject copy. Concerning the object and VP chains, CR is faced with the remnant movement configuration again: The object copy in the topicalised VP copy is not c-commanded by the object copy in SpecTP and thus not part of the object chain. However, it is in an identical position as the object copy in the lower link of the chain. CR therefore deletes both object copies that are sisters of V and daughters of VP. Also, the lower VP copy in Spec ν P undergoes deletion. Subsequent HHM moves ν to T and the resulting complex to C (V2 in German). Last Resort *do* insertion takes place to provide a host for the inflectional affixes in ν and T (32b). Note that I abstract away from the head finality of V, ν , and T in German in order to keep the trees in line with the others in the paper for reasons of simplicity and comparability.

(32) CR ① \gg HHM ② in VP fronting of remnant VP: Do-support

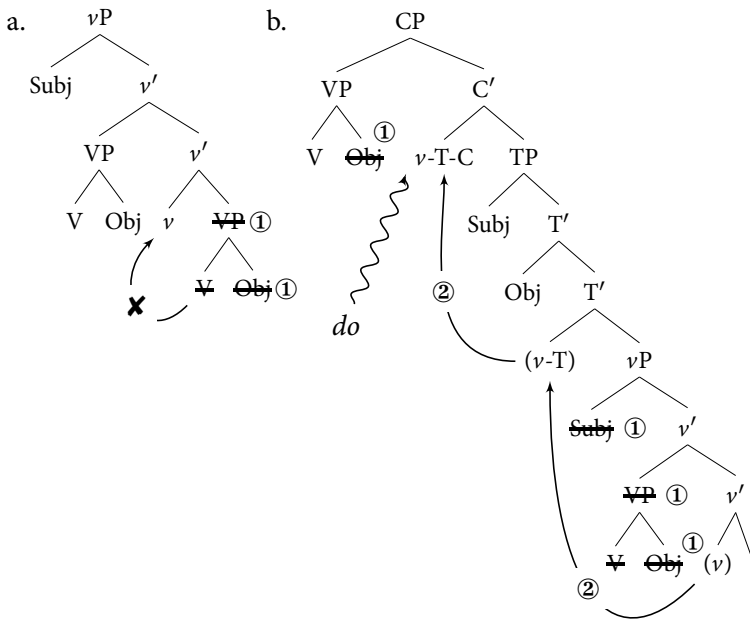

The resulting structure contains only one copy of the lexical verb as the sole constituent of VP in SpecCP – which gives the illusion of a fronted bare head – and shows *do*-support lower in the clause.

The same result obtains when the fronted constituent is a remnant ν P. Again, the object moves to SpecTP just like the subject does. When C is merged, the

entire νP phase is sent off to PF. Within the νP there are no multiple copies of any constituent yet and HHM can move V to ν after CR has applied vacuously (33a). In syntax, the νP is fronted to SpecCP. After transfer of the CP phase to PF, CR applies and deletes the copy in the lower link of each the subject chain and the object chain. Since for both subject and object there is a further copy in an identical position to that of the respective lower link (daughter of VP for the object, daughter of νP for the subject), namely the copy in the upper νP copy, that, too, gets deleted by CR. The lower copy of the νP itself also undergoes deletion. Therefore, subsequent HHM of the lower V- ν head to T is impossible since the head has been deleted along with the νP copy and *do*-support takes place (33b).

(33) CR ① \gg HHM ② in VP fronting of remnant νP : *Do*-support

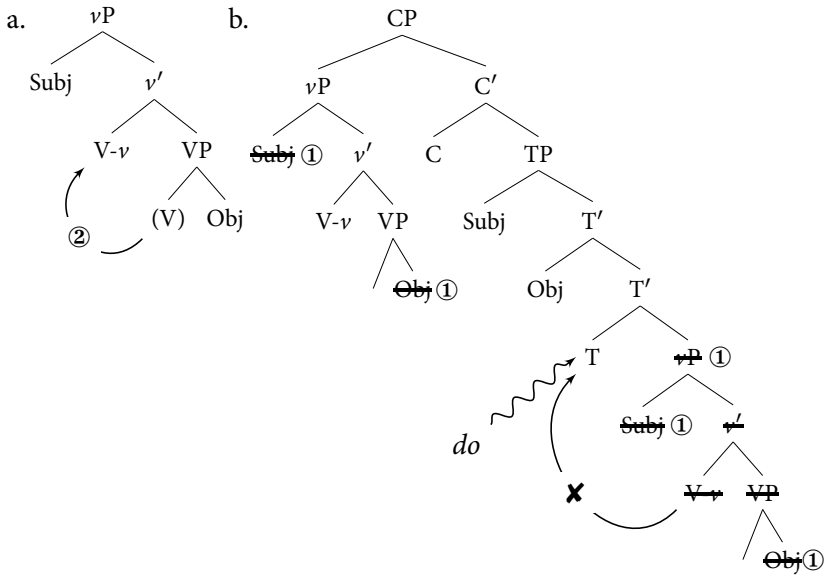

In both remnant VP movement and remnant νP movement, the order CR \gg HHM results in *do*-support just as it does with full VP/ νP movement. Languages with this order that employ remnant movement instead of \bar{A} -head movement in V fronting thus show a symmetric pattern of *do*-support.

6.2. HHM applies before CR: verb doubling

If the order CR >> HHM with remnant VP movement leads to the same result of *do*-support as it does with standard VP movement, then the reverse order can be expected to give rise to verb doubling in remnant VP movement just as it does with full VP movement. This is indeed the case. First, the whole VP moves to Spec ν P. Then, T is merged and attracts both the subject and the object. After merge of C, the ν P is transferred to PF where HHM applies first moving V to ν . CR subsequently deletes the whole lower VP copy since it occupies the lower link of the movement chain (34a). The upper VP is then copied again and moved to SpecCP in syntax. CP is sent off to PF and the complex head V- ν is first moved to T before CR deletes the object copy in the lower chain link, the one in an identical position in the fronted VP, and the VP copy in Spec ν P (34b). In the end, the structure contains two copies of V and thus shows verb doubling as expected.

(34) HHM ① >> CR ② in VP fronting of remnant VP: Verb doubling

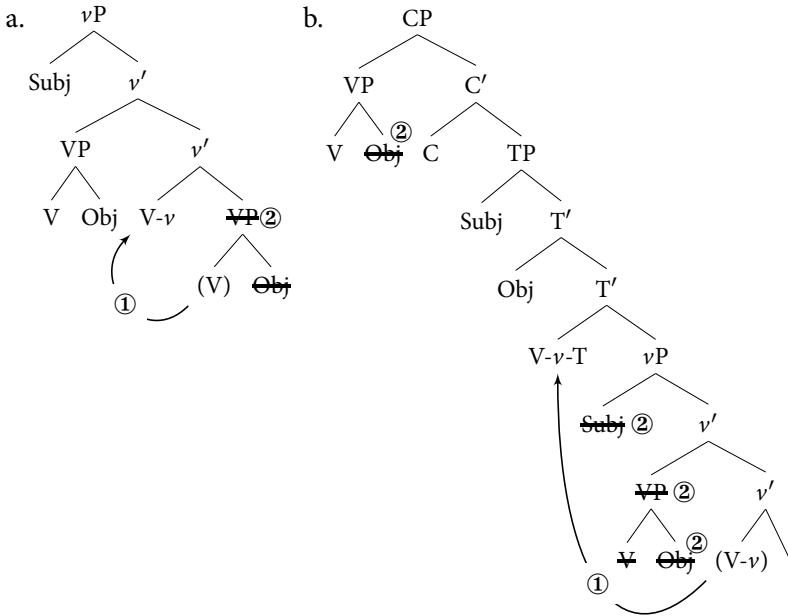

The same holds in the case of remnant ν P movement. In syntax, the object and the subject are moved to SpecTP. C is merged and the ν P phase arrives at PF. HHM creates the complex head V- ν , CR applies vacuously (35a). Next, the

whole ν P raises to SpecCP and the CP phase is sent to PF. HHM applies first moving V- ν out of ν P to T. Subsequent CR deletes the subject and object copies that are daughters of ν P and VP, respectively, and the entire lower ν P copy. Eventually, two copies of V- ν survive, one in the ν P in SpecCP and the other as part of the complex V- ν -T head which gives a surface pattern of verb doubling (35b).¹³

(35) HHM ① \gg CR ② in VP fronting of remnant ν P: Verb doubling

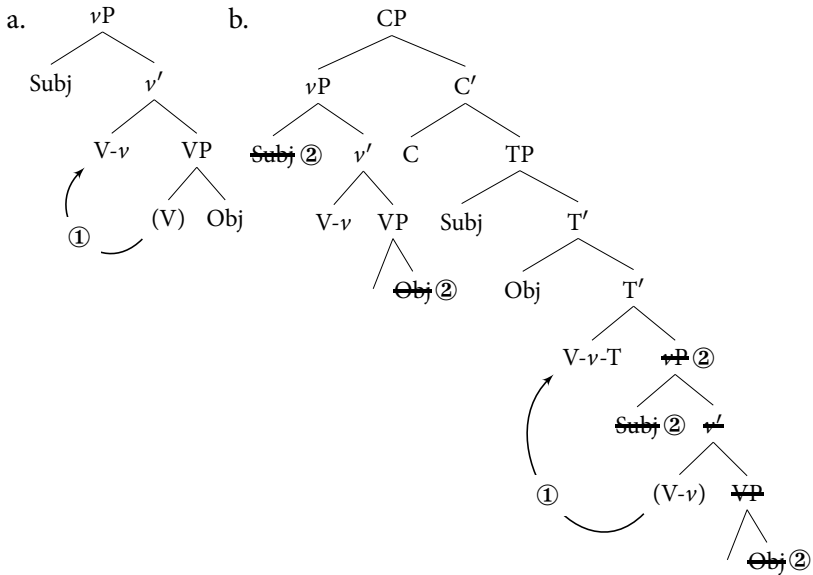

A language that exemplifies the above is Polish, which shows verb doubling in both V and VP fronting contexts (36).

- (36) a. *Wypić* (to) Marek *wypije* herbatę, ale nie wypije
 drink.INF TO Marek drink.FUT tea but not drink.FUT
kawy.
 coffee
 ‘As for drinking, Marek will drink tea, but he will not drink coffee.’

¹³Note that, analogous to full ν P movement, verb doubling is predicted not to occur if the V- ν complex does not move to T and hence is deleted along with the lower ν P copy. Therefore, HHM \gg CR does not lead to verb doubling in languages that move a ν P in VP fronting structures and a remnant ν P in V fronting structures.

- b. *Wypić herbatę (to) Marek wypije, ale nie wypije*
 drink.INF tea TO Marek drink.FUT but not drink.FUT
kawy.
 coffee
 ‘As for drinking tea, Marek will drink it, but he will not drink
 coffee.’ (Bondaruk 2012: 55)

According to Bondaruk (2009, 2012), V fronting involves remnant movement rather than \bar{A} -head movement in Polish because the language has independently available scrambling movement of the object. Furthermore, the fronted category is claimed to be a (remnant) ν P rather than a (remnant) VP, since the two verb copies have to agree with regard to their aspectual specification, which is assumed to be hosted on ν .

7. Summary and conclusions

As I have shown in this paper, the answer to the second question in section 1, whether the attested asymmetric and symmetric patterns of verb doubling vs. *do*-support can be derived under Minimalist assumptions about syntax and PF, is yes. This is achieved by introducing a strict language-specific order between Chain Reduction and Head-to-Head Movement at PF. The account is able to derive a language’s pattern from two of its properties: (i) the order of operations at PF and (ii) whether it has \bar{A} -head movement or remnant movement in V fronting structures. Whether the fronted constituent is V(P) or ν (P) has no influence on the pattern. With the exception of languages that have no V-to-T movement and front (remnant) ν Ps rather than (remnant) VPs, the order HHM \gg CR leads to verb doubling no matter the type of movement (\bar{A} -head, VP/ ν P, or remnant VP/ ν P). In contrast, the reverse order CR \gg HHM gives rise to *do*-support for both VP/ ν P and remnant VP/ ν P movement but to verb doubling for \bar{A} -head movement. The effect of the order of operations is thus neutralised by this kind of movement. The reason is that it does not create a chain that early Chain Reduction could apply to because such a chain is precluded by the Chain Uniformity Condition (Chomsky 1995). A summary of the influence of the order of operations at PF and the moved constituent on the repair strategy is given in (37).

(37) *Repair strategy depending on order of operations and constituency*

Surface	Constituent	Order of PF operations	
		HHM >> CR	CR >> HHM
VP fronting	complete VP/vP	verb doubling	<i>do</i> -support
V fronting	remnant VP/vP	verb doubling	<i>do</i> -support
	bare V/V- <i>v</i>	verb doubling	verb doubling

Turning back to Asante Twi predicate clefts, their asymmetric pattern of verb doubling is not so puzzling anymore. It is simply the result of Asante Twi's underlying order of PF operations CR >> HHM and its use of \bar{A} -head movement. This order generally results in *do*-support, which is why Asante Twi shows *yo* insertion in VP clefts. Nevertheless, the effect of the order is neutralised by \bar{A} -head movement in favour of verb doubling, which is why Asante Twi pronounces two verb copies in bare V clefts. This pattern falls out from the proposed analysis just as naturally as the symmetric patterns of Hebrew, German, and Polish do.

Furthermore, a language with a pattern of *do*-support in V fronting and verb doubling in VP fronting has not yet been found. The account predicts this typological gap because the pattern is impossible to derive. In order to show verb doubling in VP fronting, a language would have to have the order HHM >> CR (and possibly also V-to-T movement). However, as mentioned above, this order results in verb doubling for V fronting, too, independent of whether it involves \bar{A} -head movement or remnant movement. The analysis thus not only accounts for the Asante Twi predicate clefts but also for the typology of verb doubling in predicate fronting by deriving all and only the three attested patterns to the exclusion of the unattested one. Moreover, it does so with recourse to minimalist proposals about phrase structure and movement that have independently been argued for in the literature.

References

- Abels, Klaus (2001): The predicate cleft construction in Russian. In: S. Frank, T. H. King & M. Yadroff, eds, *Annual Workshop on Formal Approaches to Slavic Linguistics: The Bloomington Meeting*. Michigan Slavic Publications, Michigan, pp. 1–18.
- Abels, Klaus (2003): Successive cyclicity, anti-locality, and adposition stranding. PhD thesis, University of Connecticut.

- Aboh, Enoch Oladé (1998): 'Focus constructions and the focus criterion in Gungbe', *Linguistique Africaine* 20, 5–50.
- Aboh, Enoch Oladé (2006): When verbal predicates go fronting. In: I. Fiedler & A. Schwarz, eds, *Papers on information structure in African languages*. ZAS Papers in Linguistics 46, ZAS, Berlin, pp. 21–48.
- Aboh, Enoch Oladé & Marina Dyakonova (2009): 'Predicate doubling and parallel chains', *Lingua* 119, 1035–1065.
- Aelbrecht, Lobke (2012): What ellipsis can do for phases and what it can't, but not how. Talk given at: 'Ellipsis conference', Vigo University.
- Ameka, Felix (1992): Focus Constructions in Ewe and Akan. In: C. Collins & V. Manfredi, eds, *Proceedings of the Kwa Comparative Syntax Workshop*. Vol. 17 of *MIT Working Papers in Linguistics*, MIT Press, Cambridge, Mass., pp. 1–25.
- Arregi, Karlos & Andrew Nevins (2012): *Morphotactics: Basque Auxiliaries and the Structure of Spellout*. Springer, Dordrecht.
- Assmann, Anke, Doreen Georgi, Fabian Heck, Gereon Müller & Philipp Weisser (to appear): 'Ergatives Move Too Early: An Instance of Opacity in Syntax', *Syntax*.
- Bastos-Gee, Ana Claudia (2009): Topicalization of verbal projections in Brazilian Portuguese. In: J. Nunes, ed., *Minimalist Essays on Brazilian Portuguese Syntax*. John Benjamins, Amsterdam, pp. 132–155.
- Bilola, Edmond (1997): *Functional Categories and the Syntax of Focus in Tuki*. Vol. 2 of *Lincom Studies in African Linguistics*, Lincom Europa, Newcastle.
- Boadi, Lawrence (2008): Tense, Aspect and Mood in Akan. In: F. K. Ameka & M. E. K. Dakubu, eds, *Aspect and Modality in Kwa Languages*. John Benjamins, Philadelphia, pp. 9–68.
- Bobaljik, Jonathan (1995): Morphosyntax: The syntax of verbal inflection. PhD thesis, MIT, Cambridge, Mass.
- Boeckx, Cedric & Sandra Stjepanović (2001): 'Head-ing toward PF', *Linguistic Inquiry* 32(2), 345–355.
- Bondaruk, Anna (2009): Constraints on predicate clefting in Polish. In: G. Zybatow, U. Junghanns, D. Lenertová & P. Biskup, eds, *Studies in Formal Slavic Phonology, Morphology, Syntax, Semantics, and Information Structure*. Proceedings of FDSL 7, Leipzig 2007, Peter Lang, Frankfurt am Main, pp. 65–79.
- Bondaruk, Anna (2012): Copy deletion in Polish predicate clefting. In: E. Cyran, H. Kardela & B. Szymanek, eds, *Sound, structure and sence. Studies in memory of Edmund Gussmann*. Katolicki Uniwersytet Lubelski, Lublin, pp. 55–70.
- Borer, Hagit (1984): 'Restrictive relatives in Modern Hebrew', *Natural Language and Linguistic Theory* 2, 219–260.
- Brody, Michael (1995): *Lexico-Logical Form: A radically minimalist theory*. MIT Press, Cambridge, Mass.

- Brody, Michael (2000): 'Mirror theory: Syntactic representation in perfect syntax', *Linguistic Inquiry* 31, 29–56.
- Bury, Dirk (2003): Phrase structure and derived heads. PhD thesis, University College, London.
- Cable, Seth (2004): Predicate clefts and base-generation: Evidence from Yiddish and Brazilian Portuguese. ms., MIT, Cambridge, MA.
- Chomsky, Noam (1993): A Minimalist Program for Linguistic Theory. In: K. Hale & S. J. Keyser, eds, *The View from Building 20: Essays in Linguistics in Honour of Sylvain Bromberger*. MIT Press, Cambridge, Mass., pp. 1–52.
- Chomsky, Noam (1995): *The Minimalist Program*. MIT Press, Cambridge, Mass.
- Chomsky, Noam (2000): Minimalist Inquiries: The Framework. In: R. Martin, D. Michaels & J. Uriagereka, eds, *Step by Step*. MIT Press, Cambridge, Mass., pp. 89–155.
- Chomsky, Noam (2001): Derivation by Phase. In: M. Kenstowicz, ed., *Ken Hale. A life in Language*. MIT Press, Cambridge, Mass., pp. 1–52.
- Chomsky, Noam (2008): On phases. In: R. Freidin, C. P. Otero & M. L. Zubizarreta, eds, *Foundational Issues in Linguistic Theory. Essays in Honor of Jean-Roger Vergnaud*. MIT, Cambridge, Mass., pp. 291–321.
- Collins, Chris & Komlan Essizewa (2007): The Syntax of Verb Focus in Kabiye. In: D. L. Payne & J. Peña, eds, *Selected Proceedings of the 37th Annual Conference on African Linguistics*. Cascadilla Press, Somerville MA, pp. 191–203.
- den Besten, Hans & Gert Webelhuth (1990): Stranding. In: G. Grewendorf & W. Sternefeld, eds, *Scrambling and Barriers*. John Benjamins, Amsterdam, pp. 77–92.
- Embick, David (1997): Voice and the interfaces of syntax. PhD thesis, University of Pennsylvania.
- Fanselow, Gisbert (2002): Against remnant VP-movement. In: A. Alexiadou, E. Anagnostopoulou, S. Barbiers & H.-M. Gärtner, eds, *Dimensions of movement: From features to remnants*. John Benjamins, Amsterdam, pp. 91–125.
- Fowlie, Meaghan (2010): More multiple multiple spell-out. In: *Proceedings of GLOW 31: Principles of linearisation workshop*. Mouton de Gruyter, Berlin.
- Fox, Danny & David Pesetsky (2003): Cyclic linearisation and the typology of movement. Ms., MIT.
- Fox, Danny & David Pesetsky (2005): 'Cyclic linearisation of syntactic structure', *Theoretical Linguistics* 31, 1–45.
- Gärtner, Hans-Martin (1998): 'Review of "Nunes, Jairo (1995) "The Copy Theory of Movement and the Linearization of Chains in the Minimalist Program" Ph.D. dissertation, University of Maryland"', *GLOT International* 3(8), 16–19.
- Georgi, Doreen (2014): Opaque Interaction of Merge and Agree: On the Nature and Order of Elementary Operations. PhD thesis, Universität Leipzig.

- Grewendorf, Günther & Joachim Sabel (1994): 'Long scrambling and incorporation', *Linguistic Inquiry* 25, 263–308.
- Groat, Erich & John O'Neill (1996): Spell-Out at the interface: Achieving a unified syntactic computational system in the minimalist framework. In: W. Abraham, S. D. Epstein, H. Thráinsson & J.-W. Zwart, eds, *Minimal ideas: Syntactic studies in the minimalist framework*. John Benjamins, Amsterdam, pp. 113–139.
- Hale, Ken & Samuel Keyser (2002): *Prolegomenon to a Theory of Argument Structure*. MIT Press, Cambridge, Mass.
- Halle, Morris (1992): Latvian declension. In: G. Booij & J. van der Marle, eds, *Morphology Yearbook 1991*. Kluwer, Dordrecht, pp. 33–47.
- Harbour, Daniel (2008): 'Klivaj predika, or predicate clefts in Haitian', *Lingua* 118, 853–871.
- Harley, Heidi (2004): Merge, conflation, and head movement. The First Sister Principle revisited. In: K. Moulton & M. Wolf, eds, *NELS* 34. University of Massachusetts, GLSA, Amherst, pp. 239–254.
- Harley, Heidi & Rolf Noyer (1998): Licensing in the non-lexicalist lexicon: nominal-nominal, Vocabulary Items and the Encyclopedia. In: H. Harley, ed., *Papers from the UPenn/MIT Roundtable on Argument Structure and Aspect*. Vol. 32 of *MIT Working Papers in Linguistics*, MIT Press, Cambridge, Mass., pp. 119–137.
- Harley, Heidi & Rolf Noyer (1999): 'Distributed Morphology', *GLOT International* 4(4), 3–7.
- Hinterhölzl, Roland (2002): Remnant movement and partial deletion. In: A. Alexiadou, E. Anagnostopoulou, S. Barbiers & H.-M. Gärtner, eds, *Dimensions of movement: From features to remnants*. John Benjamins, Amsterdam, pp. 127–149.
- Hiraiwa, Ken (2005): 'Predicate Cleft in Bùli: The CP/DP symmetry', *Linguistic Analysis* 32, 544–583.
- Hiraiwa, Ken (2010): 'Scrambling to the Edge', *Syntax* 13(2), 133–164.
- Holmberg, Anders (1999): 'Remarks on Holmberg's Generalization', *Studia Linguistica* 53, 1–39.
- Kandybowicz, Jason (2008): *The Grammar of Repetition. Nupe grammar at the syntax-phonology interface*. Vol. 136 of *Linguistik Aktuell - Linguistics Today*, John Benjamins, Amsterdam/Philadelphia.
- Kandybowicz, Jason (2015): 'On prosodic vacuity and verbal resumption in Asante Twi', *Linguistic Inquiry* 46(2), 243–272.
- Karimi, Simin (2005): *A Minimalist Approach to Scrambling: Evidence from Persian*. Vol. 76 of *Studies in Generative Grammar*, Mouton de Gruyter, Berlin.
- Koopman, Hilda (1984): *The syntax of verbs: From verb movement rules in the Kru languages to Universal Grammar*. Foris, Dordrecht.
- Koopman, Hilda (1997): 'Unifying predicate cleft constructions', *Proceedings of the Twenty-Third Annual Meeting of the Berkeley Linguistics Society* 23(2), 71–85.

- Korsah, Sampson & Andrew Murphy (2015): Tonal reflexes of successive-cyclic movement in Asante Twi. Talk given at: 'NELS 46', Concordia University, Montreal, Canada, October 2015.
- Kropp Dakubu, Mary Esther (2005): The syntax of focus in Ga and Akan and the significance of related constructions. Talk given at: 'Conference on focus in African languages', Humboldt University, Berlin, October 2005.
- Lahne, Antje (2008): Where There is Fire There is Smoke. Local Modelling of Successive-Cyclic Movement. PhD thesis, Universität Leipzig.
- Landau, Idan (2006): 'Chain Resolution in Hebrew V(P)-fronting', *Syntax* 9(1), 32–66.
- Larson, Richard & Claire Lefebvre (1991): Predicate cleft in Haitian Creole. In: *NELS*. Vol. 21, GLSA Publications, Amherst, MA, pp. 53–61.
- Lasnik, Howard (1981): Restricting the Theory of Transformations. In: N. Hornstein & D. Lightfoot, eds, *Explanation in Linguistics*. Longman, London, pp. 152–173.
- Lechner, Winfried (2001): 'Reduced and phrasal comparatives', *Natural Language and Linguistic Theory* 19(4), 683–735.
- Lechner, Winfried (2004): *Ellipsis in Comparatives*. Mouton de Gruyter, Berlin, New York.
- Lechner, Winfried (2007): Interpretive effects of head movement. Ms., University of Cyprus/Stuttgart.
- Manfredi, Victor (1993): Verb focus in the typology of Kwa/Kru and Haitian. In: F. Byrne & D. Winford, eds, *Focus and grammatical relations in Creole languages*. Benjamins, Amsterdam, pp. 3–51.
- Marantz, Alec (1997): No Escape from Syntax: Don't try Morphological Analysis in the Privacy of your own Lexicon. In: A. Dimitriadis, ed., *UPenn Working Papers in Linguistics*. Vol. 4, University of Pennsylvania, Philadelphia, pp. 201–225.
- Marfo, Charles (2005): Aspects of Akan Grammar and the Phonology-Syntax Interface. PhD thesis, University of Hong Kong.
- Marfo, Charles & Adams Bodomo (2005): 'Information structuring in Akan question-word fronting and focus constructions', *Studies in African Linguistics* 32(4), 179–208.
- Muñoz Pérez, Carlos (2015): Chain formation as inclusion relations between copies. Talk given at: 'ConSOLE XXIII', University Paris Diderot, January 2015.
- Müller, Gereon (1998): *Incomplete category fronting: A derivational approach to remnant movement in German*. Kluwer, Dordrecht.
- Müller, Gereon (2009): Ergativity, Accusativity, and the Order of Merge and Agree. In: K. K. Grohmann, ed., *Explorations of Phase Theory. Features and Arguments*. Mouton de Gruyter, Berlin, pp. 269–308.
- Müller, Gereon (2014): *Syntactic Buffers*. Vol. 91 of *Linguistische Arbeits Berichte*, Institut für Linguistik, Universität Leipzig, Leipzig.
- Murphy, Andrew & Zorica Puškar (2015): Closest Conjunct Agreement is an Illusion: Evidence from gender agreement in Serbo-Croatian. Ms., Universität Leipzig.

- Nunes, Jairo (2004): *Linearization of Chains and Sideward Movement*. Vol. 43 of *LI Monographs*, MIT Press, Cambridge, Mass.
- Paster, Mary (2010): 'The verbal morphology and phonology of Asante Twi', *Studies in African Linguistics* 39(1), 77–120.
- Pesetsky, David (1997): Optimality Theory and syntax: Movement and pronunciation. In: D. Archangeli & D. T. Langendoen, eds, *Optimality Theory: An overview*. Blackwell, Malden, Mass., pp. 134–170.
- Pesetsky, David (1998): Some optimality principles of sentence pronunciation. In: P. Barbosa, D. Fox, P. Hagstrom, M. McGinnis & D. Pesetsky, eds, *Is the best good enough?*. MIT Press, Cambridge, Mass., pp. 337–383.
- Platzack, Christer (2013): Head movement as a phonological operation. In: L. Cheng & N. Corver, eds, *Diagnosing Syntax*. Vol. 46 of *Oxford Studies in Theoretical Linguistics*, Oxford University Press, Oxford, pp. 21–43.
- Puškar, Zorica (2015): Interaction of gender, number and class features: Evidence from Bosnian/Croatian/Serbian. Talk given at: 'Gender, class and determination conference', University of Ottawa, September 2015.
- Richards, Marc (2011): 'Deriving the edge: What's in a phase', *Syntax* 14(1), 74–95.
- Roberts, Ian (2010): *Agreement and head movement: Clitics, incorporation, and defective goals*. Vol. 59 of *LI Monographs*, MIT Press, Cambridge, Mass.
- Saah, Kofi & Helen Goodluck (1995): 'Island effects in parsing and grammar: Evidence from Akan', *The Linguistic Review* 12, 381–409.
- Saddy, Douglas (1991): Wh-scope mechanisms in Bahasa Indonesia. In: L. L.-S. Cheng & H. Demirdache, eds, *More papers on wh-movement*. Vol. 15 of *MIT Working Papers in Linguistics*, MIT Press, Cambridge, Mass., pp. 183–218.
- Sauerland, Uli & Paul Elbourne (2002): 'Total reconstruction, PF movement, and derivational order', *Linguistic Inquiry* 33(2), 283–319.
- Selkirk, Elizabeth (2011): The Syntax-Phonology Interface. In: J. Goldsmith, J. Riggle & A. Yu, eds, *The Handbook of Phonological Theory*. 2nd edn, Blackwell, Oxford, pp. 435–484.
- Svenonius, Peter (2004): On the edge. In: D. Adger, C. de Cat & G. Tsoulas, eds, *Syntactic Edges and their effects*. Kluwer, Dordrecht, pp. 261–287.
- Svenonius, Peter (2005): 'Extending the extension condition to discontinuous idioms', *Linguistic Variation Yearbook* 5, 227–263.
- Takano, Yuji (2000): 'Illicit remnant movement: An argument for feature-driven movement', *Linguistic Inquiry* 31, 141–156.
- Trinh, Tue (2011): *Edges and Linearization*. PhD thesis, MIT, Cambridge, Mass.
- Űrögdi, Barbara (2006): 'Predicate fronting and dative case in Hungarian', *Acta Linguistica Hungaria* 53(3), 291–332.
- van Craenenbroek, Jeroen (2010): *The Syntax of Ellipsis: Evidence from Dutch dialects*. Oxford Studies in Comparative Syntax, Oxford University Press, New York.

- van Riemsdijk, Henk (1989): Movement and regeneration. In: P. Benincá, ed., *Dialectal variation and the theory of grammar*. Foris, Dordrecht, pp. 105–136.
- van Urk, Coppe & Norvin Richards (2015): ‘Two Components of Long-Distance Extraction: Successive Cyclicity in Dinka’, *Linguistic Inquiry* 46(1), 113–155.
- Vicente, Luis (2007): The syntax of heads and phrases: A study of verb (phrase) fronting. PhD thesis, University of Leiden, The Netherlands.
- Vicente, Luis (2009): ‘An alternative to remnant movement for partial predicate fronting’, *Syntax* 12(2), 158–191.